



WIRELESS LINKS

Introduction

- Transmission of waves take place in the electromagnetic (EM) spectrum.
- The carrier frequency of the data is expressed in cycles per second called hertz(Hz).
- Low frequency signals can travel for long distances through many obstacles but can not carry a high bandwidth of data while high frequency signals can travel for shorter distances through few obstacles and carry a narrow bandwidth.

Introduction

- The noise effect on the signal is inversely proportional to the power of the radio transmitter. The three broad categories of wireless media are:
 - Radio
 - Microwave
 - Infrared

Transmission medium and physical layer

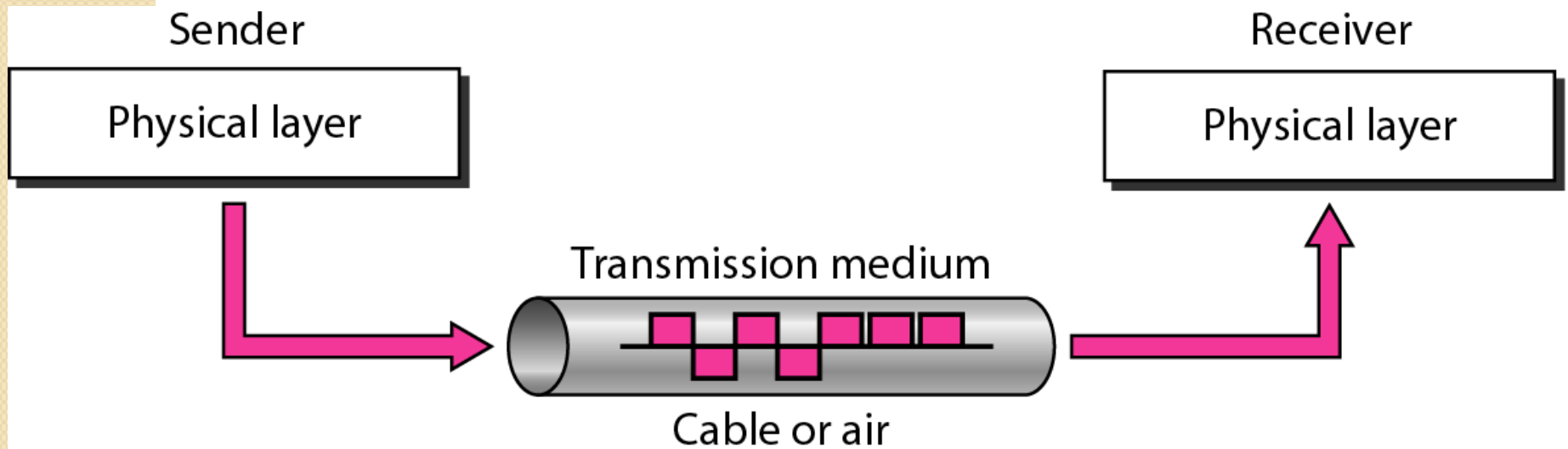

Classes of transmission media

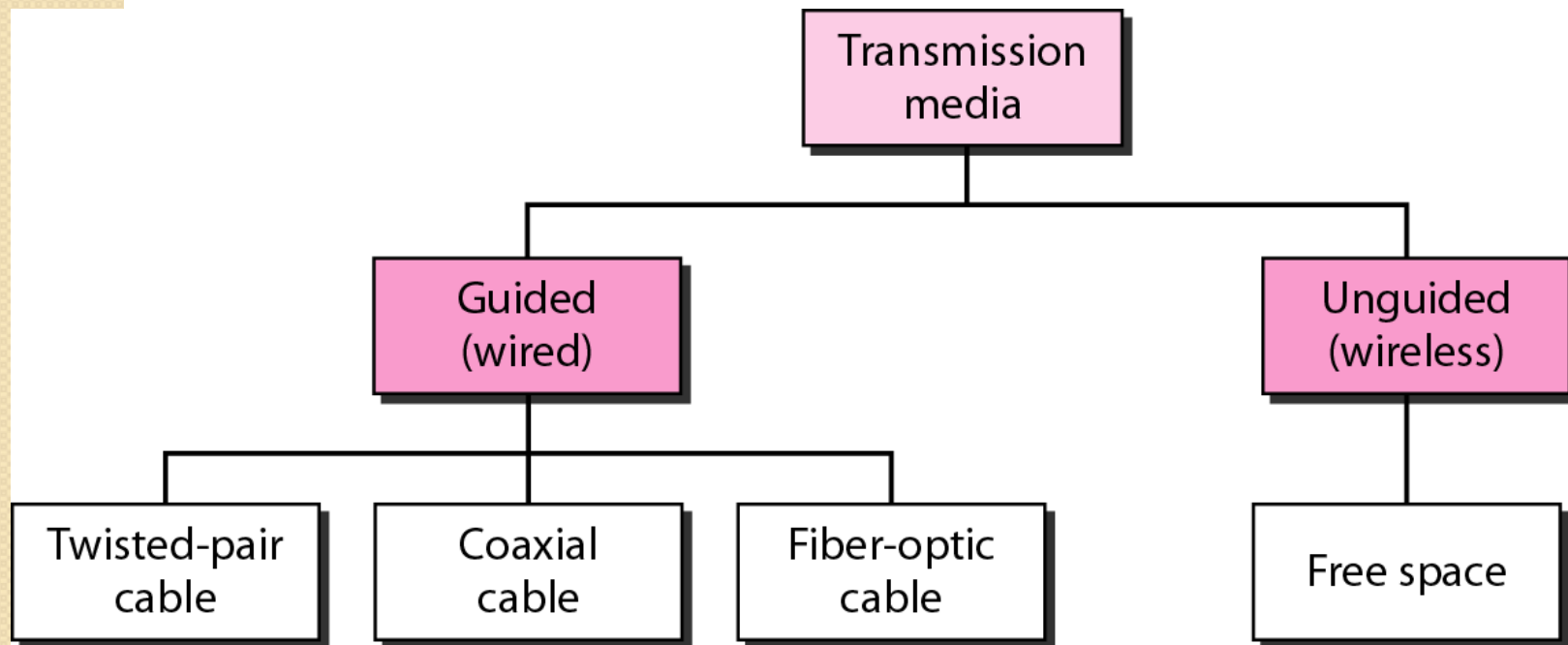

Bands

<i>Band</i>	<i>Range</i>	<i>Propagation</i>	<i>Application</i>
VLF (very low frequency)	3–30 kHz	Ground	Long-range radio navigation
LF (low frequency)	30–300 kHz	Ground	Radio beacons and navigational locators
MF (middle frequency)	300 kHz–3 MHz	Sky	AM radio
HF (high frequency)	3–30 MHz	Sky	Citizens band (CB), ship/aircraft communication
VHF (very high frequency)	30–300 MHz	Sky and line-of-sight	VHF TV, FM radio
UHF (ultrahigh frequency)	300 MHz–3 GHz	Line-of-sight	UHF TV, cellular phones, paging, satellite
SHF (superhigh frequency)	3–30 GHz	Line-of-sight	Satellite communication
EHF (extremely high frequency)	30–300 GHz	Line-of-sight	Radar, satellite

Wireless transmission waves

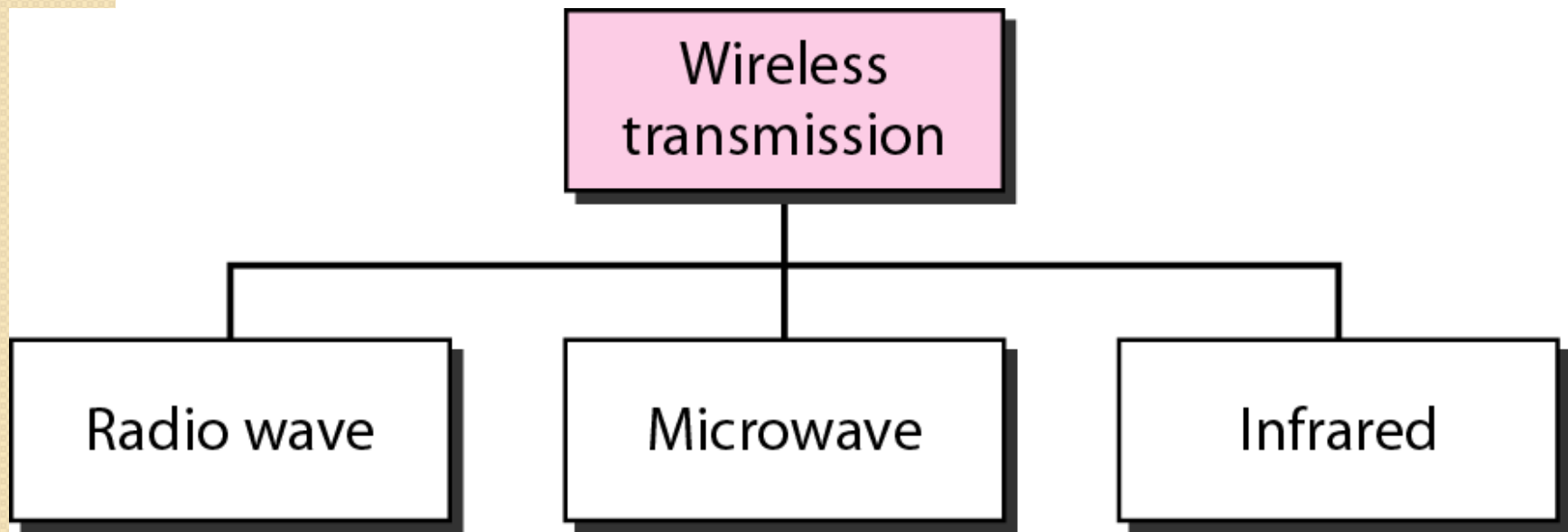



Note

Radio waves are used for multicast communications, such as radio and television, and paging systems. They can penetrate through walls.
Highly regulated. Use omni directional antennas

Omnidirectional antenna

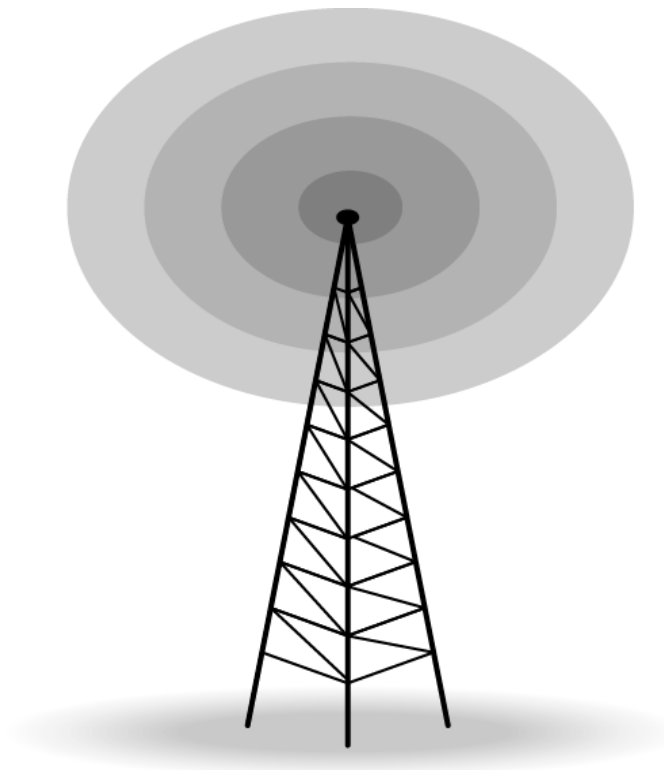



Note

Microwaves are used for unicast communication such as cellular telephones, satellite networks, and wireless LANs.

Higher frequency ranges cannot penetrate walls.
Use directional antennas - point to point line of sight communications.

Unidirectional antennas

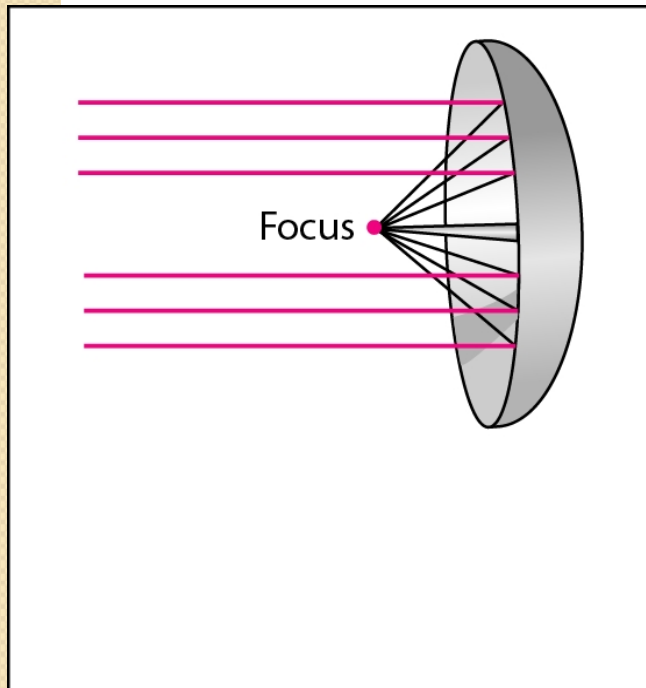

a. Dish antenna

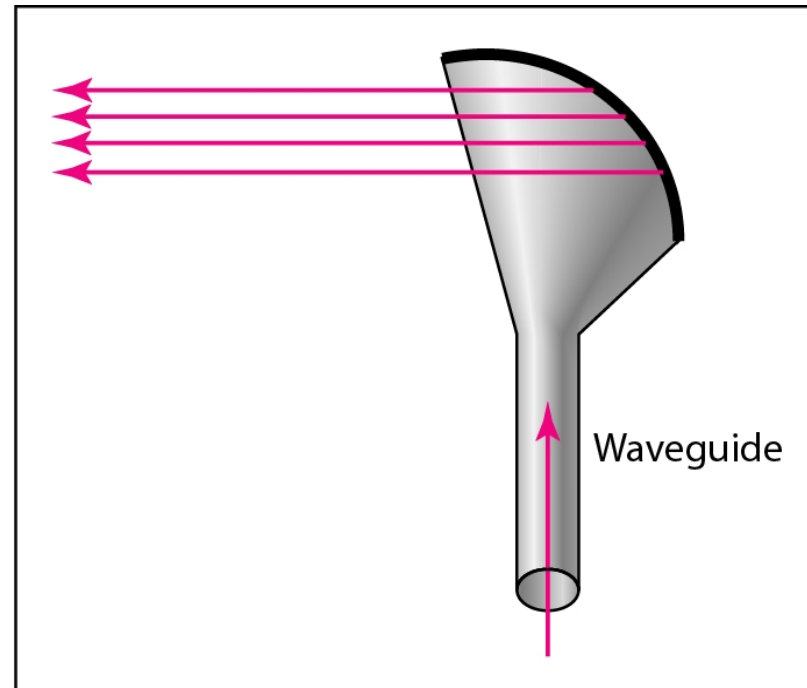

b. Horn antenna



Note

Infrared signals can be used for short-range communication in a closed area using line-of-sight propagation.

Wireless Channels

- Are subject to a lot more errors than guided media channels.
- Interference is one cause for errors, can be circumvented with high SNR.
- The higher the SNR the less capacity is available for transmission due to the broadcast nature of the channel.
- Channel also subject to fading and no coverage holes.

Applications

- Adhoc Networks
- Wireless LAN
- Radio broadcast
- Television programme broadcast
- Mobile communication

Scope of Research

- Device supporting wireless media
- Routing through wireless media
- Access Protocols for wireless media